



AMERICAN ALUMINUM

ACCESSORIES, LLC.

SECURE TRANSPORT SYSTEMS

CAMLOCKER

THE KEY TO SECURITY





From our family, to yours, thank you for your interest in American Aluminum Accessories, Inc. We manufacture a wide variety of products from high-quality toolboxes to an extensive line of products designed to meet the ever-changing needs of the Law Enforcement Community.

In 1989, we began as a manufacturer of our superior quality CamLocker toolboxes. In 1992, due to the demand for safe, secure canine transport for a nearby Law Enforcement Departments, we introduced the very first in-vehicle EZ RIDER K-9 Container.

We have continuously grown and expanded our products, catering to the needs and wants of our valued customers and high profile clientele. Over the years as your needs have changed, we have evolved and expanded our products to include Inmate Transport Systems, Vault Systems, K-9 Training Aids, Contraband Containment and Animal Control Systems.

We strive daily to manufacture the finest products available and we always welcome the input you provide to continue our improvements. We would like to thank each and every one of our valued customers. It is with our deepest appreciation we thank you, the Law Enforcement Community for your dedication and service.

We look forward to serving you.

TABLE OF CONTENTS

00	Our Story	20	Home Kennel
01	Table of Contents	21	Collapsible Crates & Standard Crate
02	K9 Introduction	22	Vault Systems
03	Platform System	23	UP Vault
05	K9 Unit Make & Model Chart	28	Vault Gallery
06	E/Z K9 Platform with Storage	29	SUV Universal Vaults
07	E/Z Glider Door	30	Inmate Transport Van
08	Tahoe New Design Features	31	Inmate Transport Size Chart
10	K9 Accessories	34	Screen Systems & Door Panels
11	Additional Options	36	Animal Control
12	EZ AC System	38	Animal Control Slide In
13	K9 Electronics	39	Obstacle Courses
14	Cool Guard Plus M910 Series	41	Testimonials
18	E/Z Rider Universal Utility Slide In	42	CamLocker
19	E/Z Rider Universal Utility	69	Employee Directory



AMERICAN ALUMINUM
ACCESSORIES, LLC.

PROTECTING THOSE WHO PROTECT US

We believe in service and satisfied customers.
Our technical department backs up every product we build.

Customer Care Center:
Toll Free: 1-800-277-0869

Monday through Friday 8:00 am to 4:30 pm
Customer Service, Purchasing, or quote Assistance on All Products: 1-800-277-0869

WWW.EZRIDERONLINE.COM



HANDLERS CHOICE

From the inception of K-9 transport, American Aluminum has taken input from Officers in the design and function of the various platforms. From the standard window and door panels to the RESCUE and COOLGUARD PLUS created to keep their K-9 partners safe, Officers from around the country have helped refine the platforms to add safety, and performance to the product.

The utility of small department vehicles was enhanced when we were asked to make a unit for the K-9 officer and an inmate, the 1/3-2/3 unit was created. We value the safety and security of the officers using our K-9 inserts as well as comments and suggestions for design modifications.

We would like to thank and honor those in the field of law enforcement for their contributions and their dedication to serve and protect. Our over 30 year relationship with the K-9 community has made the American Aluminum K-9 Platform systems the Handlers Choice.

MAXIMIZE YOUR K9 PARTNER'S COMFORT



OUR ATTENTION TO DETAIL MAXIMIZES YOUR K-9 SPACE

The Original E/Z Rider K9 Platform unit is fully contoured for a vehicle specific fit. The K9 Insert is made of .125 mill finish aluminum, with a .080 lid and .063 door panels. The unit is fully welded with vertical front bars for added strength and area window for easy cleaning. Seamless Base Pan fully welded and specific fit contouring to allow canine leg safe ease upon entry and exit. Base extends door sill to door sill utilizing all available space and allowing for easy rinsing and cleaning without damage to vehicle. Vented top's allows for maximum airflow from vehicles with existing factory rear A/C and heat. All platform units include perfectly contoured Aluminum Window Guards and Aluminum Door Panels. Window Guards are powder coated black. Door Panels are contoured, smooth, flat design for ease of install. Complete Hardware kit with installation instructions included.

PLATFORM SYSTEMS CONTINUED



Powder coat tested for 1000 hour salt fog chamber test per ASTM. Powder coat process was rated excellent. Our EZ Rider Platform System (performed on a F150 truck and Ford Interceptor SUV) tested for roof mounted airbag deployment compatibility and our system was rated excellent. Test performed by Karco Engineering.

Sedan models weight 225 lbs. and SUV models weight 325 lbs.



K9 UNIT MAKE & MODEL

	K9 PLATFORM	K9 PLAT W SHELVING	K9 PLAT W RAMP	K9 PLAT W RAMP & SHELVING	EXTENDED K9 PLAT	K9 1/3 2/3	K9 1/3 2/3 REVERSE	EXTENDED 1/3 2/3 K9
Ford Explorer 2020 - 2024	✓	✓			✓	✓	✓	
Ford Explorer 2011-2019	✓				✓	✓		✓
Ford Expedition 2018 - 2024	✓				✓			✓
Ford Expedition 2007-2017	✓				✓			
Ford F150 2015 - 2024	✓	✓	✓			✓		
Ford F150 2009-2014	✓							
Ford F250/350 2017 - 2024	✓	✓	✓	✓		✓		
Ford F250/350 2011-2016	✓							
Ford Taurus 2012-2019	✓							
Chevy Tahoe 2021 - 2024	✓	✓			✓	✓		
Chevy Tahoe 2015-2020	✓	✓			✓			✓
Chevy Tahoe 2000-2014	✓							✓
Chevy Crew Cab 2014-2018	✓	✓	✓			✓		
Chevy Crew Cab 2019 - 2024	✓	✓	✓			✓		
Chevy Suburban 2015-2020	✓				✓	✓		
Chevy Suburban 2021 -2024	✓					✓		
Dodge Charger 2011 - 2024	✓							
Dodge Durango 2011 - 2024	✓					✓		
Dodge Crew cab 2019 - 2024	✓	✓					✓	
Dodge Crew cab 15-18	✓					✓		

!ATTENTION!

1/3 2/3 IK units that utilize factory OEM seats are noted with a **RED** check. 1/3 2/3 IK units that utilize AAA built aluminum seats are noted with a **GREEN** check.



EZ K9 PLATFORM WITH STORAGE

AMERICAN ALUMINUM ACCESSORIES INTRODUCES THE EZ K9 PLATFORM WITH 1/3 STORAGE

The storage portion of the unit was designed for trucks and suvs to assist handlers in their ever growing need for secure storage.

Features

- The shelving unit utilizes all the safety features of our fully welded front panels with vertical bars.
- Three tiers of shelving
- Each shelf comes standard with raised front perforated edges to allow secure tie down locations.
- All shelves are built from .125 Mill Finish aluminum for added strength.
- Available with a Cam locking Vault drawer (18"X18"X6") for an added level of secure storage. (Optional)
- Vehicles available- Ford F250/350, Dodge Crew cab, Ford Explorer, Chevy Tahoe (see chart on page 5)

2020 ISUV



EZ GLIDER DOOR

This is a redesign of our EZ Rider K9 Platform Units Emergency Exit Door.

- This gives our Emergency Exit Door a new Slim design. It is over an inch thinner than the previous door.
- Equipped with Heavy Duty ball bearing slides for a smooth and QUIET action.
- Spring loaded Easy Touch overhead latch for quick release and a Bump Stop to ensure the door doesn't lock in the open position.



TAHOE NEW DESIGN FEATURES

FAN GUARD

- The fan guard shelf was designed with the mind set of giving ample room for the massive side curtain airbag to drop unimpeded while also protecting the vehicle OEM trim from a high energy K9. As an added feature it gives the fan a slight downward angle to have a greater cooling effect on the K9 as to not blow straight across over the top of the K9's back.

ELECTRONIC K9 PROTECTION

- Due to the design of the lower pan mounting brackets there is no guessing with pan placement. It can only go in one position.
- The unit comes with horizontal bubble trim for the lower pan and rear partition edge and the door opening. This is an added protection for clean out as well as a superb finish.



TAHOE NEW DESIGN FEATURES

- The unit is designed to easily accessorize with the K9 Cool Guard Plus system with rescue. The pan has a pass through cutout for the Cool Guard gas strut as well as having pre punched mounting points for the gas strut brackets on the door panels and lower pan bracket. This gives precise mounting every time.
- The 2021 Tahoe was designed with comfort and ease of access in mind. The front partition was moved back five and a half inches from the B pillar to allow full track back for the driver and the passenger. This gives a great amount of leg room and comfort for taller officers and large duty belts or tactical vests.
- While the officer has an exceptional amount of room kennel space for the K9 was not sacrificed. The kennel measure 65.75" passenger to driver and 35.5" front to rear.
- This is a great feature that was put in place due directly to feedback from tall handlers.
- The floor pan brackets are constructed of 11ga cold rolled steel. The brackets mount directly to the passenger and driver side rear seat mounts with points of contact at both front and rear of pan.
- The unit is also equipped with 2 upper brackets also constructed of cold rolled steel giving 6 mounting points
- The unit was designed with a straight rear partition to not protrude into the rear of the vehicle allowing a wide range of rear cargo storage option.





E/Z REMOVABLE DIVIDER

Our E/Z Divider allows you to convert your existing platform unit into a dual canine transport containment system. The divider is removable and fully adjustable. Constructed of aluminum with a center door and sliding latch to allow access to the other side of the cage.

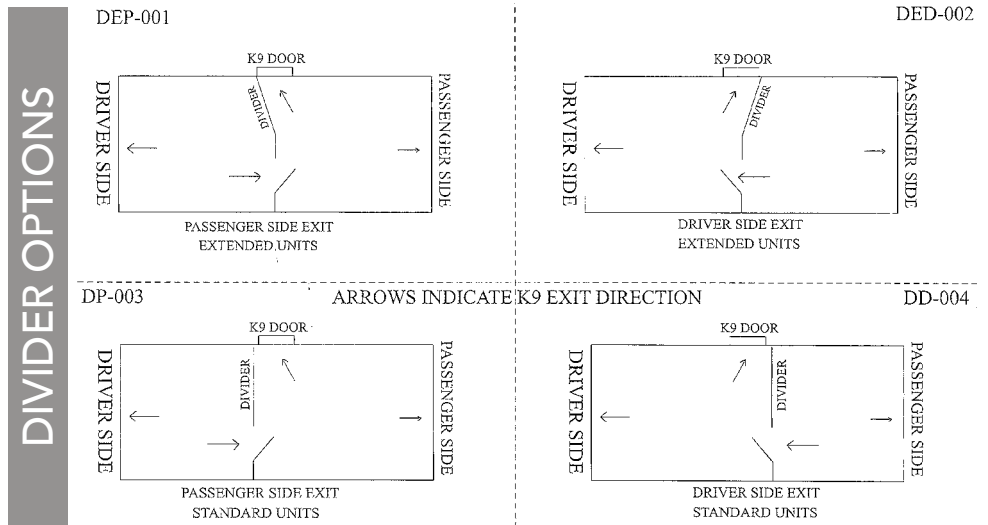

E/Z SPILL PROOF WATER DISH

A must for your K9 Transport system, our E/Z spill proof water dish is the perfect accessory to any and all of our K9 transport systems. Constructed of mill finish aluminum with 1 gallon water capacity. Our spill proof water dish comes with a easily removable mounting system.



E/Z RUBBER MAT (INCLUDED WITH K9 INSERT)

The E/Z Rubber Mat is a bare bones necessity for any and all of our K9 transport systems. Heavy duty 1/8" thick for maximum durability and custom fit to your specific E/Z Rider Transport model, it provides a safe, comfy barrier for your canine from the aluminum platform base.

BLOCK OUT KIT

Our block out kits are made from high quality 1/8th inch thick polycarbonate with optional 3/4 inch round holes or 1 1/2 square holes with radius corners. The block out kit is a great way to decrease the spread of K9 hair throughout your vehicle while still allowing air flow. We offer the block out as a set for front and rear or they can be purchased independently.



WINGS

*All polycarbonate pieces, including front and rear polycarbonate wings and headliner covers as well as block out kits, are also offered in aluminum. For handlers with high energy K9's that have a tendency to chew, this is a great option. Systems are airbag tested. Please call for details.

ALUMINUM WINGS



OPTIONAL (\$+)

POLYCARBONATE WINGS



STANDARD

POWDER COAT

AAA is a 100% manufacturer. We start with sheets of high quality aluminum and when we are done you have a finished product. We offer a full powder coat service. Our standard color for K9 units is Text Black this color helps reduce silhouetting of the K9 in the vehicle. We also offer Tele grey as seen below.

TELE GREY



OPTIONAL (\$+)

TEX BLACK



STANDARD

Powder Coat color options available in battle ship grey, white, tele grey & matte black.

NEW EZ AC SYSTEM FOR FORD AND CHEVROLET TRUCKS

Introducing our EZ AC system for Ford F series and GM pickup trucks. The system utilizes the rear AC vents mounted under the front seats. This is an upgrade for your K9 partner. On the K9 side of the cage the vents are strategically placed on the lower section of the front partition blowing towards the rear partition. For a Platform one vent on driver side and one vent on passenger side. After long heated activity upon returning to the vehicle and laying down the placement will cause the cool air to come directly in contact with the K9 quickly.





COOL GUARD PLUS SERIES

Protect your department's investment in your canine partner or animal control unit with our in-vehicle Coolguard Plus (or CGP). Our Coolguard Plus gives you peace of mind and will self-activate to rapidly cool your canine when dangerous temperatures are detected inside the vehicle. The lethal temperature for an average size Law Enforcement K-9 is 103 to 107 degrees Fahrenheit for approximately 5 minutes.

The Coolguard Plus comes complete with:

- Display monitor
- Two temperature sensors with humidity for heat and cold
- A cool temperature setting for temperatures colder than 30 degrees Fahrenheit
- Automatic dual window drop
- High speed fan with dual fan option
- Fan guard and wiring harness
- Digital display for reading the vehicle temperature
- A unique horn alarm pattern
- Heat index and humidity display
- Self-diagnosing alerts with logs
- An equipment test
- Drive disable so the alarm will not go off while driving
- Alarm lights active- two outputs for flashing any lights connected on the vehicle (flashing lights not included)
- Low battery page function
- Paw Protect to remind the handler to not forget the K9 before leaving the vehicle
- Installation instructions and free technical support are included
- Full 1 year warranty against any defects



E/Z COOLGUARD PAGER

Sold separately as an additional option for our E/Z Coolguard, the Pager ensures that should you be outside of hearing range for the horn alarm, you will be notified by a page that your Coolguard system has been activated. Installation instructions and free technical support are included. Full 1 year warranty against any defects.



E/Z R.E.S.C.U.E. REMOTE DOOR OPENING SYSTEM

The E/Z Rescue Remote Door Opening System allows the officer to unlock, open and release the K-9 via remote transmitter. Should the officer be outside of the patrol car and need immediate assistance, his K-9 partner is a push of a button away. E/Z Rescue comes complete with an actuator motor, small key chain remote and new 120 pound hydraulic shock. Installation instructions, door and pan etched rescue bracket placement and free technical support are included.



COOL GUARD PLUS M910 SERIES

FUNCTIONS

The M910 series keeps the functions of the standard style Coolguard: Monitors the temperature, has 2 settings, high and low, to toggle from four season changes, rolls windows down, turns fan on, and sends a pulse for the horn and pager, and still universal for all makes and model vehicles.

New Functions:

- 2 outputs for emergency lights
- Pager signal alerts for alarm AND low battery
- Heat alarm calculates for heat AND humidity
- 2 temp probes now for best temp accuracy
- Alarm set for hot AND cold temps
- 2 Fan outputs
- Vehicle in drive disable- disarms the alarm while the vehicle is in drive
- 5 minute disable- disarms the alarm after the 10 minute cooldown for 5 minutes, and then rearms by a touch or after the 5 minutes has timed out
- Equipment test- press the equipment test button and then press alarm functions individually or press start test to test all functions
- Alarm history- in settings, the history for both equipment test and alarm history are stored for service and diagnostics
- Paw Protect- Alarm turns on with vehicle, stays monitoring after vehicle turns off, must remove dog and press PawProtect button to turn off.

OPERATION SCREEN

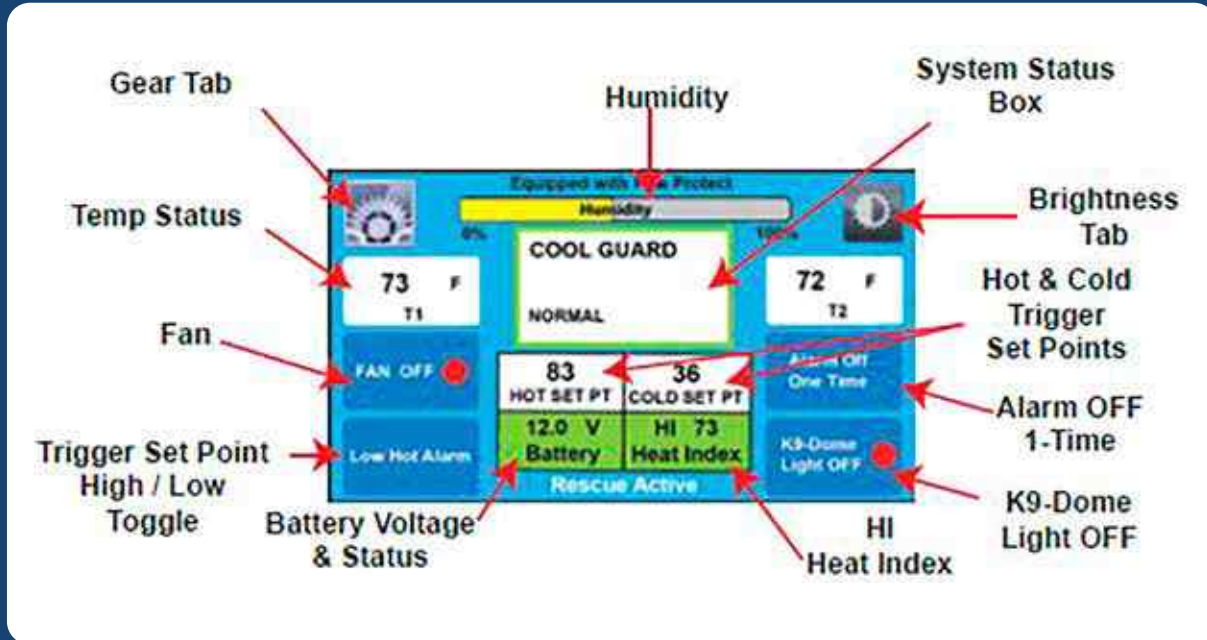

HOW TO USE:

Once wiring has been completed, turn on the key/ignition. This will power up the unit, it will cycle through our logo and contact info, and then scroll to the cool down screen. This gives the handler 10 minutes to cool down the vehicle before arming the K9 alarm system. An additional 5 minutes can be added at this screen if needed when starting up the vehicle. Then the unit will automatically scroll to the main operation screen, or be bypassed to go straight to the armed operation screen.

Once the cool down time has been elapsed or bypassed, the home screen will be displayed. This will show the 2 temps, the humidity %, and display a green normal square for in park and acceptable temperature, a black square for in gear and alarm can not sound, a yellow square for heat warning, and a red square for hot or cold alarm, and a yellow or black square for different system faults.

ALARM STATUS INDICATORS



HOW TO TEST YOUR SYSTEM

At any time you can test your system after it is installed, simply press the gear button and then equipment test, or press the equipment test button—depending on which screen you are at. Then press the items you wish to test or press system test and it will test all that are hooked up. When complete, press the gear and then operation to return to the home screen to resume normal operation.



COOL GUARD PLUS M910 SERIES

ALARM AND EVENT HISTORY

Both Histories are used for documentation. This is to show how many times the alarm was tested, what failed during the test if it failed, and when the alarm went off from hot or cold temperatures. This is used for troubleshooting, as well as if the agency needs to know when something failed. All this documentation is saved to the unit permanently. We still recommend that the unit be tested at least once a week, and/or no less than once a month.



TO TURN OFF YOUR UNIT

Turn the key/ ignition off. This will make the display screen go dim and the screen will beep at you to indicate ignition has been lost. After this, the alarm will continue to monitor but is looking for the paw protect button to be pressed. This means to get out, remove the dog, and press the paw protect button located just inside the cage on the clear poly by the grab handle to turn off the alarm and discontinue monitoring. After pressing the paw protect, the alarm will turn off





E/Z RIDER UNIVERSAL UTILITY VEHICLE SLIDE IN

E/Z RIDER UNIVERSAL UTILITY VEHICLE SLIDE IN

The E/Z Rider Universal Utility Slide-In aka "UUV" is a universal canine transport solution for those wishing to utilize the cargo area of their SUV, while allowing for the middle seat area to remain free and in an upright position. Hinged front door with folding T-handle lock and emergency escape rear drop down window. Comes fully assembled and can also be used for off-duty, in-house containment. Features includes a removable base and rubber mat for easy cleaning. Available in Full Size (for larger SUV's) and Down Size models (for smaller SUV's and 2-compartment units).



E/Z Rider Universal Utility Slide-In Chart	DIMENSIONS	VEHICLE TYPE
Full Size UUV	45"W x 36"D x 29"H	Expedition/Suburban/Tahoe
Two Compartment UUV	45"W x 36"D x 29"H	With Divider/Two Doors
Down Size UUV	38"W x 33"D x 29"H	Explorer/Interceptor/Durango
Civilian Explorer	33"W x 33"D x 29"H	For Civilian Explorer Only

FS 2 comp UUV

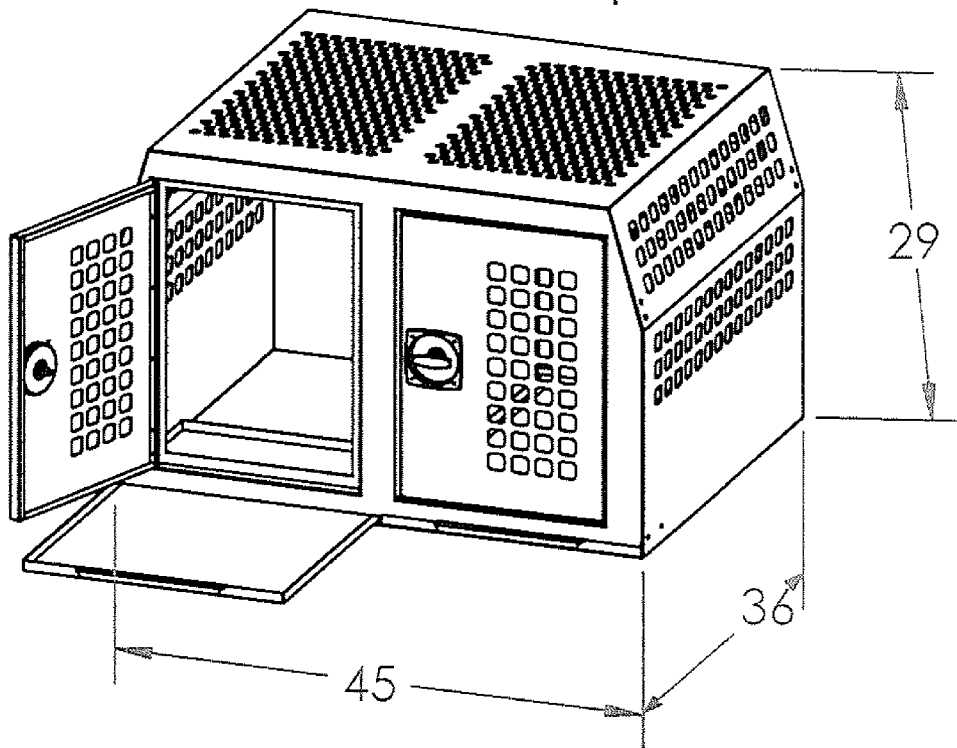

THE CONVENIENCE OF K9 TRANSPORT AND STORAGE SOLUTIONS IN ONE

Our E/Z Rider Universal Utility Combo offers the convenience of K9 transport and storage solutions in one! The Combo Unit comes with attached 2 drawer storage unit and top storage shelf area. The storage drawers are 8" deep and also come with the Camlocker locking t-handle for additional security. A solid unit, but storage area can be detached easily if need be by removing 6 bolts. K-9 Portion features removable base pan for easy cleaning, and includes our heavy-duty fitted K9 rubber mat. Available in Full Size (for larger SUV's) and Down Size models (for smaller SUV's).

UUV PRODUCT	PRODUCT	DIMENSIONS	COMMENTS
Combo Down Size	E/Z UUV-Combo Unit for Small Size SUV	Dog Side: 30" W x 48" D x 29" H. Drawer 10" W x 28" D x 10" H	Does not fit commercial Explorer
Combo for Commercial Explorer	E/Z UUV-Combo Unit for Commercial Explorer SUV. Dog sidewidth folding t-handles. All drawers have Camlocker locks.	Dog Side: 25" W x 37" D x 26" H. Drawer: 16" W x 37" D with a 9" and 7" H drawer on top and 5" H basket.	
Combo Full Size	E/Z UUV-Combo Unit Full Size with rubber mat	Dog Side: 29" W X 34" D Drawers: 16" W x 8" H X 34" D	
UUV Down Size	Fits Explorer Interceptor SUV, Durango, Tahoe and Commercial Vehicles	38" W x 33" D x 29" H	
UUV Full Size	Fits Expedition PPV and Suburban	45" W x 36" D x 29" H	
UUV Two Compartment	E/Z Two Compartment UUV with Rubber Mat	45" W x 36" D x 29" H	

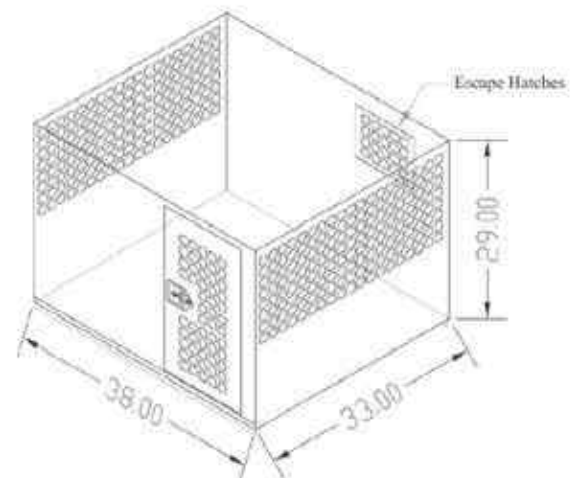
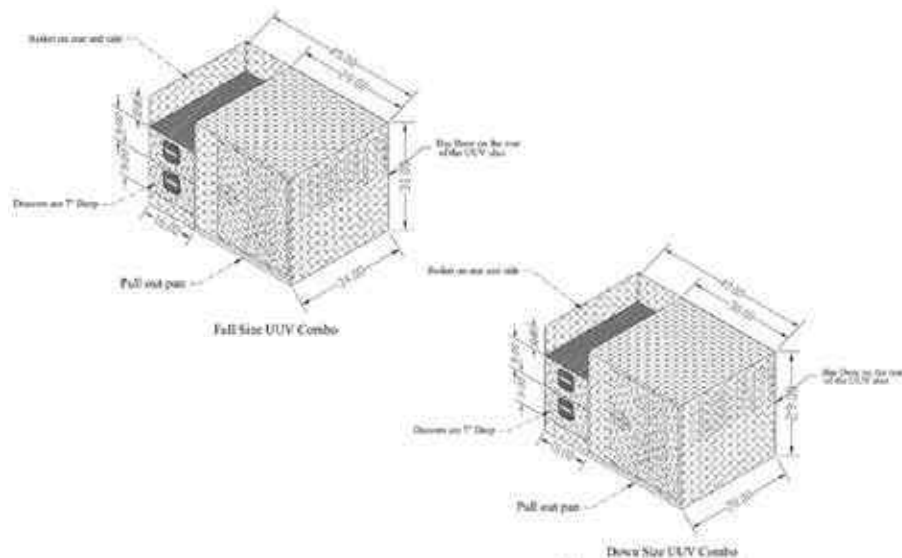
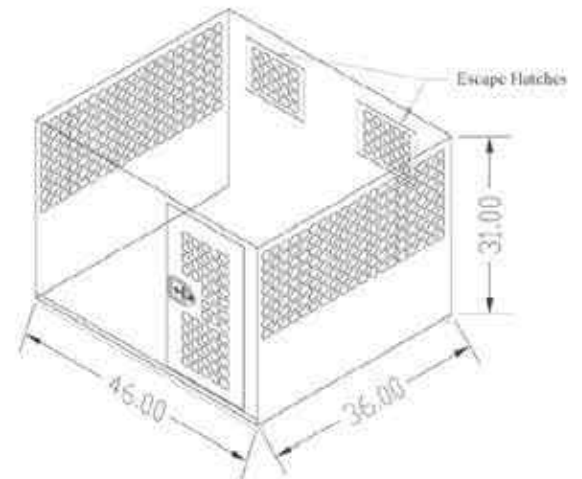
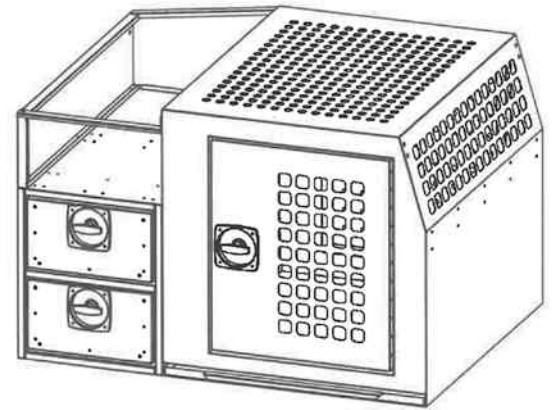

HOME KENNEL

Features

- Dog house comes with adjustable vents on each side, removable top with easy access latch and is insulated
- Sides are .100 aluminum with aluminum finish
- Floor frame, door 12" tall legs are .125 aluminum with aluminum finish
- Powder coat
- Secure lock and latch covers
- Locking folding t-handle
- Pvc covered floors are sloped toward the drain for easy cleaning and draining
- Anti-rust hardware



COLLAPSIBLE & STANDARD CRATES



COLLAPSIBLE CRATE & STANDARD CRATE SIZE MEASUREMENTS			
SIZE	WIDTH	LENGTH	HEIGHT
LARGE	25"	36"	27"
XL	27"	42"	30"
XXL	32"	48"	32"
E/Z-Crate *Non collapsible	25"	36"	27"





CAMLOCKER

AMERICAN ALUMINUM

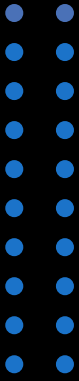
A decorative graphic consisting of two vertical columns of blue dots, with the left column having 12 dots and the right column having 11 dots.

Vault Systems are designed to store weapons and equipment securely in your vehicle.

STANDARD FEATURES

- Mill finish and powder coated aluminum.
- Slide out drawer(s) come with our Cam-Lock and Simplex Combination locking mechanisms.
- Interior carpet, exterior top carpet. Interior weapon foam (optional).
- 4" basket on top.
- Can be custom designed to the specifications required by your agency or personal preference. This includes the number, sizes, and location of drawers.

"UP" VAULTS

- Come with 11-gauge steel brackets that attach to the OEM bolts of the vehicle for an easy and secure install.
- These brackets raise the vault from the floor of the vehicle to allow access to the spare tire from the factory placement and store any additional equipment.



Single Drawer Vault



Command Vault

TWO DRAWER VAULTS WITH ELECTRONIC BASKET



Electronics basket can be added to any vault

AAA UP VAULT



#1 Seller

Vault Systems are designed for Law Enforcement use to keep equipment and ordinance secure in Sedan or SUV vehicles. The Vault systems are lightweight, yet rugged, built of mill finish. Standard features include: slide out drawer(s), CamLocker locking mechanism, interior carpet, exterior top carpet. A top basket, black matte powder coat, and optional interior weapon foam. Load it and lock it knowing your equipment is safe and secure.

Our relationships with Law Enforcement agencies around the world, has given American Aluminum the opportunity to design and manufacture many variations of our Vault Systems. Agencies have specified number of drawers, size of drawers, and location. We have even designed command centers with pull out marker boards to communicate with the team on-site. Pricing and availability will vary with the requested design. A sales professional stands ready to talk with you about the available configurations shown here.

Featured above is the new and improved "UP" vault for the new Ford Interceptor 2020! The new UP vault features 11 ga steel brackets... 5 easy parts that attach to the OEM bolts of the vehicle for an easy and secured install. The vault outer measurements are 44"Wx24"Dx8"H. It designed to allow the vault to be positioned in a way that allows most rear partitions. The vault also allows for the spare tire to stay in place but it leaves enough clearance for it to be taken out. Brackets are 11" from the floor.



UP VAULT



The Dodge Durango Up Vault fits years 2011-2020. 41"Wx24"Dx8"H. Bracket is 11" from the floor. Comes powder coated matte black and the basket is included.

Another top seller is the new Up Vault for the Chevy Tahoe. The new raised Tahoe Vault has a "U" shaped bracket 10"H. VT below is 48"x28.5"x12". It comes standard matte black with basket and carpet on top.



All American Aluminum vaults have carpet on top to reduce noise.

VAULT SYSTEMS CONTINUED



Single Drawer Vault



Command Vault

UNDER THE SEAT TRUCK VAULT

One of our newest product line features the Under the Seat Truck Vault. These vaults are designed to keep your items safe and secure while not taking up space in your truck. These vaults are built for Ford, Chevrolet, and GMC's. Designed perfectly to fit under your back seat of your truck. These vaults are built with the CamLocker locking t-handle with slide out drawers.



VAULT SYSTEMS CONTINUED



Standard features include: CamLocker locking mechanism, interior carpet, exterior carpet, top basket and powder coated matte black. Additional options include: weapon foam, Simplex locks and map drawers.



THE ULTIMATE IN QUALITY AMERICAN MADE CRAFTSMANSHIP

Hand crafted and assembled by expert craftsmen means the vault will operate as designed for years and years to come.

Your high value equipment will be secure for transport locked tight with the CamLocker system with proprietary keying mechanism available only through American Aluminum.

Lightweight and built to last. American Aluminum Vault systems come in many configurations to fit your vehicle and secure the equipment you use to do your job.

Built for Sedans and SUVs, we have a Vault that will exceed your transport needs.

VAULT GALLERY

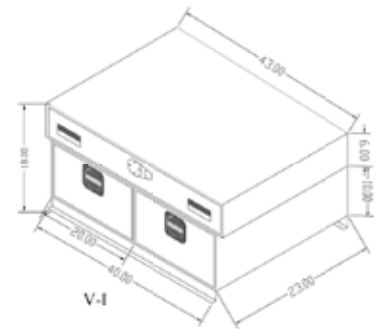
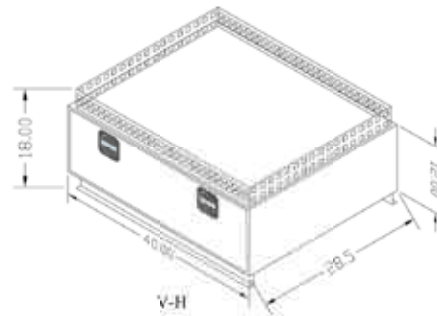
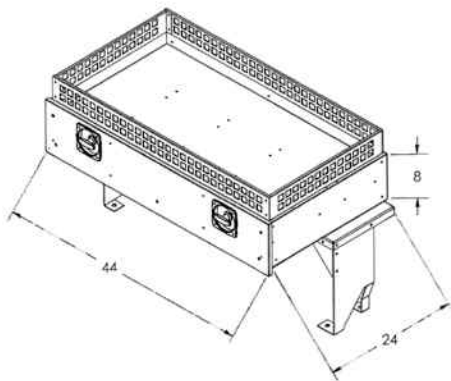
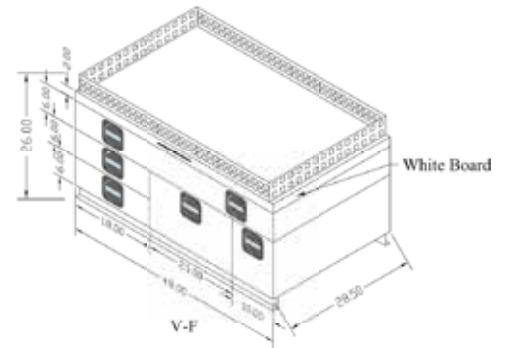
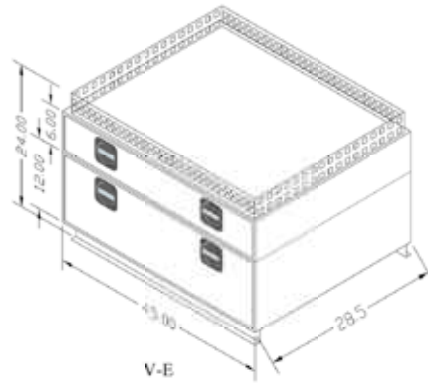
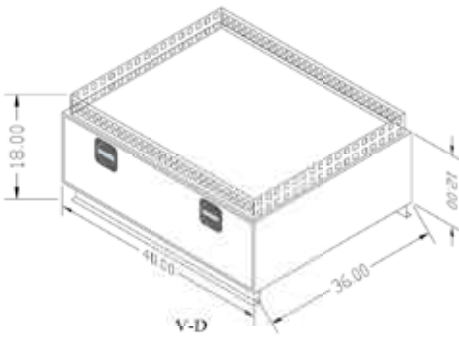
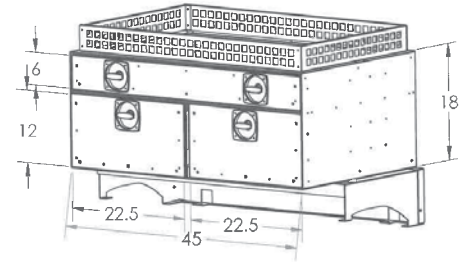
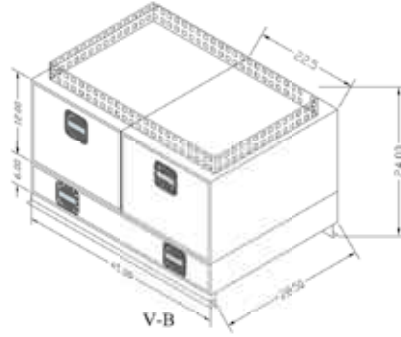
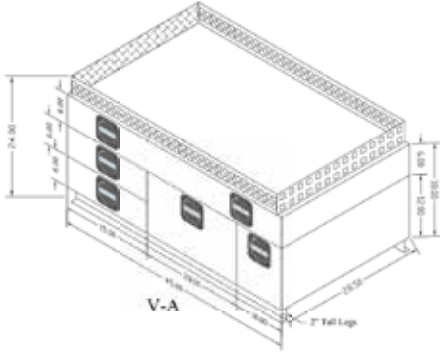

SUV UNIVERSAL VAULT SETUPS

This vault is a 41x24x8 vault that was originally built for the Dodge Durango. We have added more holes to the bottom of the vault to be able to mount it to the ISUV bracket and the 21 Tahoe bracket. The Durango bracket is made from .125 mil finish aluminum. The other two are made from 11GA CRS.

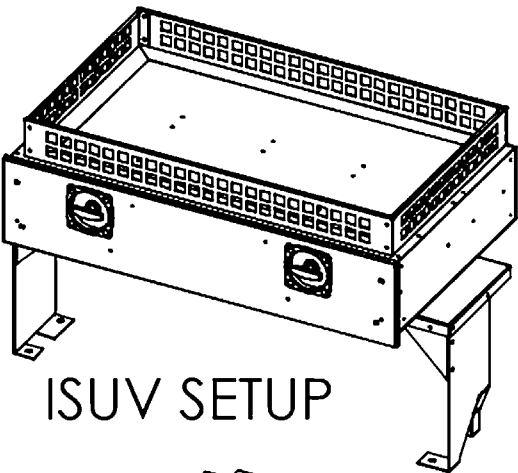

ISUV SETUP

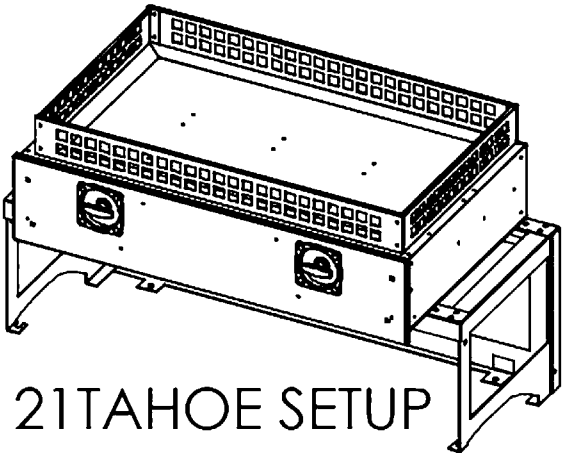

21TAHOE SETUP

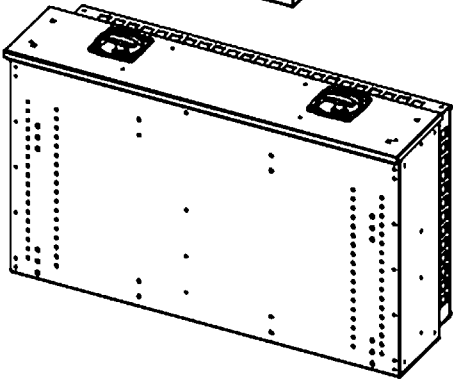

41x24x8
Universal
vault

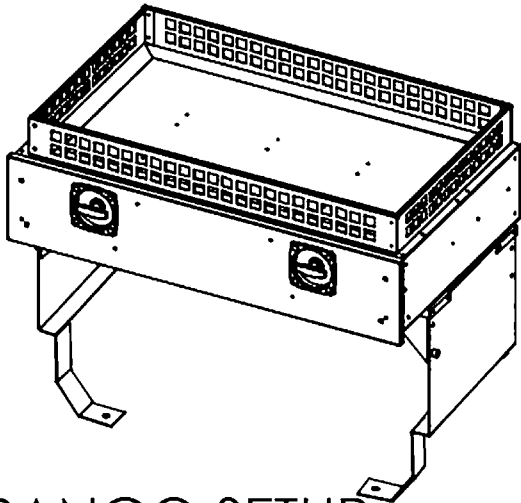

DURANGO SETUP



INMATE TRANSPORT VAN

American Aluminum manufactures safe and secure transport systems for inmates, originally designed to slide in the Ford Econoline vans. A lot has changed since the first units were designed, manufactured and installed 25 years ago. Multi-compartment designs, polycarbonate covers on openings, and emergency front exit windows are an example of new features that have been added over the years.

Standard features now include seat belts for every passenger, 6000 pound "bursting strength" slam latches with lockable T-handles, LED security recessed lighting, non-skid seat covering and a smooth interior, sealed to prohibit the hiding of contraband.

We offer Inmate units for the Ford Transit and GM/GMC vans.

Screen systems are available for Ford E-Series, Ford Transits and all GM/GMC Passenger vans.



INMATE TRANSPORT

ONE (1) COMPARTMENT UNIT:



TWO (2) COMPARTMENT UNIT:



TWO (2) COMPARTMENT UNIT:



THREE (3) COMPARTMENT UNIT:



IT SIZE GUIDE					
Unit	Compartments	Length	Width	Height	Seats
Transit LOWLWB (148"WB)	1	120.00"	60"	49.5"	12
Transit LOWLWB (148"WB)	2-F to B	120.00"	60"	49.5"	12
Transit LOWLWB (148"WB)	2- L to R	120.00"	60"	49.5"	11
Transit LOWLWB (148"WB)	3	120.00"	60"	49.5"	11
Transit LOWRWB (130"WB)	1 Comp	96"	60"	49.5"	8
Transit LOWRWB (130"WB)	2-F to B	96"	60"	49.5"	8
Transit LOWRWB (130"WB)	2- L to R	96"	60"	49.5"	7
Transit LOWRWB (130"WB)	3	96"	60"	49.5"	7
Transit MIDLWB (148"WB)	1	120.5"	58"	59.5"	12
Transit MIDLWB (148"WB)	2-F to B	120.5"	58"	59.5"	12
Transit MIDLWB (148"WB)	2- L to R	120.5"	58"	59.5"	11
Transit MIDLWB (148"WB)	3	120.5"	58"	59.5"	11
Transit MIDRWB (130WB)	1 Comp	104	58"	59.5"	10
Transit MIDRWB (130WB)	2-F to B	104	58"	59.5"	10
Transit MIDRWB (130WB)	2- L to R	104	58"	59.5"	9
Transit MIDRWB (130WB)	3	104	58"	59.5"	9
Transit HighLWBEL(148"WB)	2- L to R	150"	58"	70"	13
Transit HighLWBEL(148"WB)	3	150"	58"	70"	13
Transit HighLWB(148"WB)	2- L to R	125.5"	58"	70"	12
Transit HighLWB(148"WB)	3	125.5"	58"	70"	12
Chevy Std. (135"WB)	2- L to R	96"	60"	49.5"	9
Chevy Std. (135"WB)	3	96"	60"	49.5"	9
Chevy Extended (155"WB)	1	115"	60"	49.5"	12
Chevy Extended (155"WB)	2-F to B	115"	60"	49.5"	12
Chevy Extended (155"WB)	2- L to R	115"	60"	49.5"	11
Chevy Extended (155"WB)	3	115"	60"	49.5"	11

INMATE TRANSPORT

INMATE TRANSPORT UNIT STANDARD & EXTENDED VAN

FEATURES:

- Designed to Accommodate Factory Installed Rear Air or Auxiliary HVAC System.
- Modular design for transfer from one van to another van of the same make and length.
- Built-in seating with Non-Skid-resistant covering over all seating area.
- High strength seat belts. (48" and 60" long). 60" accommodates larger size prisoners.
- Emergency front exit window provided with every unit, access from either side
- Doors include a Poly Carbonate covered security window/view-port
- 6,000 pound "bursting strength" Slam latch with key lockable Cam-Handle locks.
- NO ACCESS to any lock, handle, or opening/closing device from the inside the unit.
- L.E.D. security-recessed interior compartment lighting is included
- All controls accessed from control switch in the driver area on lockable console.
- Overhead ductwork for rear factory A/C & Heat or for Auxiliary A/C and heat included.
- The Front Bulkhead allows for First Aid and Fire Extinguisher Installation.
- Smooth interior for safety and sealed to prevent hiding of any contraband.
- Non-rusting aluminum containers allow less down-time for washing and disinfecting.
- Light weight for fuel Efficiency and vehicle longevity.
- 3-Year Warranty on the basic Modular Unit.
- 1-year warranty on interior LED lights.

Ford Transit midroof



ADDITIONAL OPTIONS (\$+):

- New hitch step
- Camera system
- Intercom systems
- Under bench drawer
- Food door
- Cushion
- Solid drop doors
- Outside exhaust vents
- Side step

INMATE TRANSPORT- ADA ACCESSIBLE



With our wheelchair accessible transport system, a restraint chair lift is included in your choice of a two or three compartment with the ADA section being one of those compartments. The new design allows different custody levels and genders to be transported at the same time along with a restraint chair.

SCREEN SYSTEMS

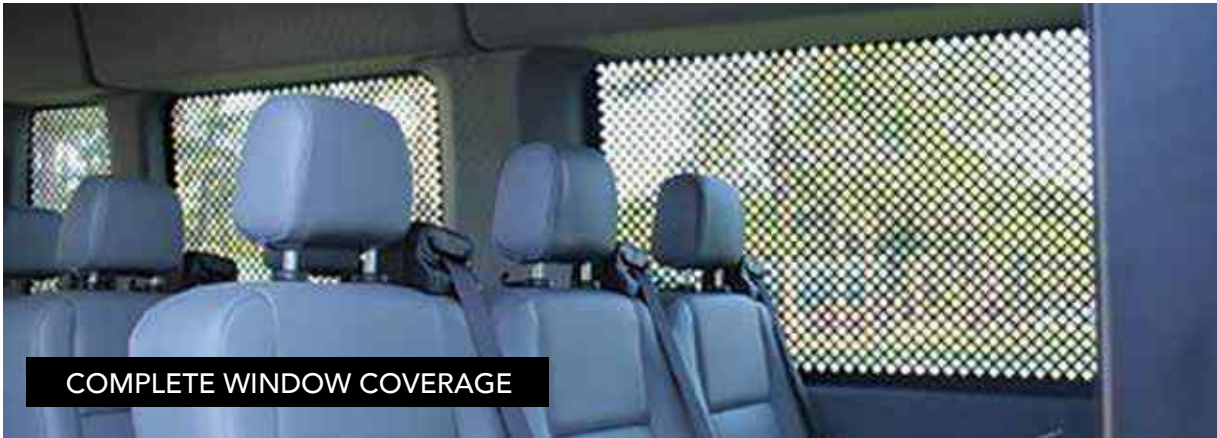

Quick install E/Z Security Screen Systems for Ford or GM 12 & 15 Passenger Vans

OUR ATTENTION TO DETAIL SECURES TRANSPORTATION

Screen systems are available to convert passenger vans into secure inmate transport vehicles. Screen systems are available for Ford Transits and GM 12 and 15 passenger vans that include complete window coverage and front partition.



SCREEN SYSTEMS & DOOR PANELS CONTINUED



**STANDARD LENGTH
12 PASSENGER**

**EXTENDED LENGTH
15 PASSENGER**

- 16 gauge galvaneal steel window guards
- 0.125" thick aluminum front partition
- 3/16" poly carbonate in partition window
- 1/2" diamonds punched in window guards & 1 1/2" radius squares punched in front partition





American Aluminum manufactures two high quality Animal Control products. Slide-in truck bed units and in-van animal control units. Made from high quality aluminum, the units are lightweight, which promotes fuel economy and will never rust, providing years of dependable service. The rugged aluminum can handle anything your animals try to do to escape and the floor drains in each compartment allow for easy cleaning.

ANIMAL CONTROL CONTINUED

The in-van Animal Control unit was designed to fit the top selling cargo vans from Ford Transit, GM, and Dodge. Form fit to maximize transport space and designed with the animal control handler in mind. Secure storage for the officer's gear and made from lightweight, easy to clean aluminum.

*** Must be installed at American aluminum ***

INCLUDES:

- Insulated walls and ceiling
- Aluminum sheeting of walls and ceiling
- All doors have catch pole perforations for easy access
- AC vent into each cage
- Drain in each cage
- All locks keyed the same
- Folding t handle locks
- LED lighting
- Removable pan in each cage
- Bottom cages have $\frac{3}{4}$ " perforations
- Top cages have $\frac{1}{4}$ " perforations
- Lockable storage compartment behind bulkhead
- Diamond plate floor
- Polycarbonate covered window on the center of the bulkhead
- **Rear passenger cage top and bottom is accessible from inside the van



The last thing you need when handling a stray animal is fighting with your transport vehicle. Attention to detail is a trademark at American Aluminum and we have designed in features that AC officers have told us helps them do their jobs.

The craftsmanship is evident in the custom fit and ease of use for the animal control officer. Every element of the design is tested before the vehicle is released by production and reviewed by customer service before you are notified the vehicle is ready for service.



ANIMAL CONTROL SLIDE IN

The Animal Control Slide-in unit is designed to fit into the bed of a pick-up truck which instantly converts the vehicle into an Animal Control Unit. The high grade aluminum means the unit will be in service for many years and can be re-installed into a new vehicle for years and years of service from the unit. The unit includes secure storage for the officer's gear. Constructed from lightweight, easy to clean aluminum, the individual animal compartments have drains for easy cleaning, fans in each compartment, protected LED lighting, heavy duty nontoxic rubber liner, powder coated WHITE, top rail, all lockable compartments, all locks keyed the same, catch pole in each door.

INCLUDES:

- Protected fans
- Protected LED interior LED lighting
- Drain in each compartment
- Heavy duty non toxic rubber mat
- Powder coated white
- Top rail
- All lockable compartments
- All locks keyed the same
- Catch pole hole in each door

JUMPS : BRICK WALL : WHITE WALL : GREEN WALL CHAIN LINK : WINDOW JUMP : PICKET FENCE : BROAD JUMPS



- Brick wall, white wall & green wall are powder coated, certified ASTM B117-09 to exceed 2,000 hrs of salt water spray testing.
- All aluminum panels measure 48"W x 35"H x 1 1/4" thick. Stand adds 1" to the height.
- Polycarbonate top guard is 1/8" thick.
- Chain link Fence, Polycarbonate side panels are 1/8" thick (1 on each side). Aluminum frame and chain link fence inside.
- 1 1/4" thick. Polycarbonate top guard is 1/8" thick.
- Window Jump is powder coated white. Window measures 30"W x 30"H. Window sits vertically from ground. Polycarbonate top guard around window.
- Picket fence, 1/2" PVC picket slats on 1 1/8" aluminum panel. 1 1/2" thick. Polycarbonate top guard on top.
- Broad jumps (Hurdles) set of 4, aluminum frame with 1/2" PVC guards across top.

OBSTACLE COURSES

CONTINUED

OBSTACLES : CRAWL : A FRAME : CAT WALK



- Crawl is 4 ft wide x 16" tall x 8 ft long. Top is 2" thick diamond plate aluminum panel, interior bracing, simulated lattice sides.
- A Frame is 4 ft wide x 6 ft tall. 3 ft landing deck on one side attached to a 45 degree ramp. Aluminum structure covered with white PVC and non abrasive safety walk. A Frame angle can be expand to a larger angle for novice training.
- Cat Walk, 6 ft tall x 8 ft long x 2 ft wide. 2 ft wide handler's deck mounted on side. Aluminum frame work, running surfaces, 1/3" PVC covered with non abrasive safety walk.
- Ladder at one end with removable safety panel for novice training. 10 ft ramp at opposite end set at 4 degree angle.

MILITARY COURSE



- Hurdles (set of three) are 48" wide and 36" tall with three fixed horizontal slats and three slats which are removable. This allows for the hurdle to be adjusted to heights of 18", 24", 30" or 36".
- A Frame is constructed of non slip materials. Cleats are included for traction/safety. Can be adjusted in height to a max of 6 ft in increments of 1/2". Support chains on each side of the A frame as well as a way of adjusting the A frame height.
- Dog Walk, 12 ft narrow, level walk and narrow decline ramp. Constructed of non-slip vinyl material with cleats for safety of the K9.
- Double Stairway, 8' height and 24' in length. Constructed of non-slip material.
- The window obstacle has removable slats which allow for the obstacle to be set at 18", 24", 30" or 36". Top section slats are fixed at 73".
- Tunnel Crawl is 18" in diameter and 8' in length.
- Barrel: 24"Dx35" • 24"D x 70" • 24"D x 105"L

TESTIMONY 1

K9 Officer Pratte with the Bow, NH Police Department was involved in a serious accident. He was rear ended on the highway resulting in substantial damage and totaling his cruiser.

Officer Pratte "Just wanted to say thanks because the AA insert kept K9 Roxy safe and she made it out uninjured.



TESTIMONY 2

"Just wanted to say thanks for building a good product IT SAVED MY K9 PARTNER FOR SURE. We will be putting another one in my new car." Officer Wingfield



TESTIMONY 3

While on the interstate this officer and his canine partner was rear ended on the interstate at 70 mph... We are proud to say that his canine partner was not harmed during this crash, the K-9 platform did get slightly bent but did not collapse and done exactly what it was built to do.

TABLE OF CONTENTS

- 41** Camlocker Tool Boxes
- 42** Camlocker Buggy Boxes
- 43** Features
- 47** Camlocker Classic
- 49** Camlocker King
- 51** Camlocker Xtra Deep & Wide
- 53** Camlocker Slim
- 57** Camlocker RV Box
- 59** Camlocker UTV & Side Mount
- 62** Fit Guide & Options
- 63** Hunting Accessories



CAMLOCKER

WE TAKE PRIDE IN SUPPLYING THE BEST ALUMINUM TOOL BOXES AND ACCESSORIES ON THE MARKET.

We supply American Hand Crafted, high quality aluminum toolboxes and truck accessories throughout the United States. Our exclusively designed aluminum tool boxes and accessories come with carbon steel, hefty chrome plated t-handles, insulated lids and felt lined boxes with tool trays.

Cam-Locker tool boxes are made of .063 Gauge construction and use a unique "cam-lock" mechanism to keep your tools secure.

These boxes are hand crafted in the USA with attention to detail. The full length lid inserted with insulation out-performs all other truck tool box lids.

The interior is felt lined throughout the tub of the box including the bottom for easy cleaning, a convenient sliding tray makes storing your small hand tools easily accessible and heavy-duty shocks allow for a smooth but firm opening and closing of the lid. Cylinders carry a 1- year, powder coat and structure carry a 3- year warranty.



CAMLOCKER



AVAILABLE IN POLISHED ALUMINUM, GLOSS OR MATTE BLACK POWDER COATED FINISHES



CAMLOCKER BUGGY BOXES AND ACCESSORIES

Ride with the ease of knowing your items are safe and secure



TOOLBOXES AVAILABLE FOR:

Can-AM Defender

Polaris Ranger

Yamaha Viking

Honda Pioneer 1000

John Deere Gator

Kawasaki Mule Pro- FXT



CAMLOCKER CROSSOVER TRUCK BOX

THE KEY TO SECURITY



THE CAMLOCKER

The CamLocker Tool box by American Aluminum, is designed for the buyer who has the need for additional storage but doesn't want to compromise the style of their truck.

With chrome plated carbon steel T-Handles and a proprietary locking mechanism, the CamLocker is tough and good looking. Manufactured in the USA with stringent quality standards and designed by folks who use the product.

CamLocker is the toolbox of choice for those discriminating buyers who value both style and substance.

PRODUCT DETAILS

- 3 year structural / 1 year parts and powder coat warranty
- .063 gauge aluminum fully welded for maximum durability
- Locking t-handles with non- duplicable locks
- Camlocking mechanism connecting rods allows for convenient operation from driver or passenger side
- Removable tray
- Full length stainless steel hinges
- Easy to install with pre- punched mounting slot and Hardware included (NO DRILLING REQUIRED)
- Polished aluminum or top rated powder coat finish)matte or gloss box
- Multiple sizes available for custom fits



“

THE ULTIMATE IN
QUALITY
AMERICAN-MADE



**LOCKING
T-HANDLE**



**LOW PROFILE
3' ABOVE BED**



**STANDARD 6'
ABOVE BED**



SLIM 14" WIDE



**KING
19" DEEP**



**DEEP AND WIDE
24.5" BY 16" DEEP**



**XTRA DEEP AND WIDE
24.5" BY 19" DEEP**

FINISHES

Aluminum, Matte black, Gloss black

CAMLOCKER EXCLUSIVE FEATURES:

- 3yr structural/1yr parts and powder coat
- CamLock locking mechanism keeps tools locked securely
- Non duplicable key system
- Heavy Duty .063 gauge polished aluminum welded construction
- T-Handles open from either side for easy access
- Full length continuous stainless steel hinges
- Insulated lids outperform all others
- Weather sealed lids
- Comes with removable, sliding tool tray
- Completely carpeted throughout sides and floor
- Polished aluminum or top-rated powder coat finish (matte or gloss black)
- Side mount boxes, emergency vehicle boxes and more
- Available in Classic, King, Deep & Wide, Extra Deep & Wide, and more
- Profile styles of Standard 6" or Low Profile 3"
- Also available in .80 for your most heavy duty jobs



Our lid rails are fully welded for the durability to anchor down cargo

PROFILE OPTIONS



STANDARD



LOW PROFILE

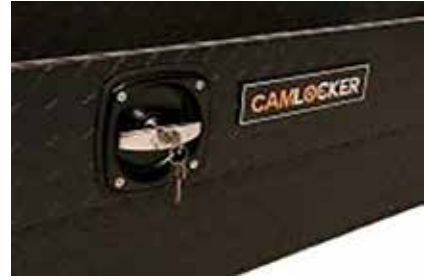

SECURE LOCK

LID OPTIONS



NO RAIL



RAIL

TUB OPTIONS

STANDARD 20" W X 14" D

KING 20" W X 19" D

SLIMLINE 14" W X 14" D

EXTRA-WIDE 24.5" W X 19" D

THE CAMLOCKER CLASSIC

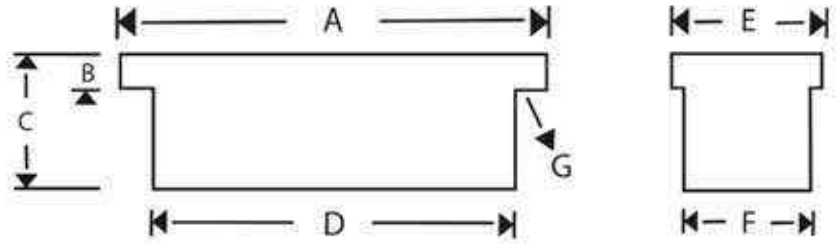

Standard: 20" Wide x 14" Deep								
Product Code	A	B	BLP*	C	D	E	F	G
CAM/S-71	71"	6"	3"	14"	60 1/2"	20"	17"	5"
CAM/S-67	67"	6"	3"	14"	56 1/2"	20"	17"	5"
CAM/S-65	65"	6"	3"	14"	54 1/2" Y - 52 1/2"	20"	17"	5"
CAM/S-63	63"	6"	3"	14"	52 1/2"	20"	17"	5"
CAM/S-60	60"	6"	3"	14"	Y - 47 1/2"	20"	17"	5"
CAM/S-54	54"	6"	3"	14"	43 1/2"	20"	17"	5"

*LP=LOW PROFILE

The CamLocker Classic box is the perfect balance of style and substance. The carpeted interior, removable storage tray, choice of profiles and top-rated powder coat finish provide the style. The superior patented locking mechanism, hefty carbon steel T-Handles and heavy duty aluminum welded construction provide the substance.

This box will turn heads all around and upgrade the image of your truck while providing secure storage to keep your valuables safe. The Classic box comes in various lengths and has profile options to make the fit into any style truck and not sacrifice the storage space.

The CamLocker Classic is one tough, good looking tool box!





INTRODUCING THE CAMLOCKER HD CROSSOVER TOOLBOX!

- Forged from Heavy Duty .080 aluminum for the toughest jobs!
- Enhanced Weatherstripping blocking all outside elements and adding superior protection for your valuables.
- Durable, fully carpeted interior to keep your gear clean and in top shape.
- Our industry-leading locking T-handles and unique, non-duplicable key system ensure maximum security without compromise.
- Over 75 key codes are used to ensure the unlikeliness of someone having the same code.
- Key codes are hidden. All codes are stamped inside in a discreet location that only a CamLocker owner would know.
- Key blanks that only CamLocker owners have access to.

Designed for law enforcement, available for you!

CAMLOCKER HD CROSSOVER TOOLBOXES

STANDARD HD

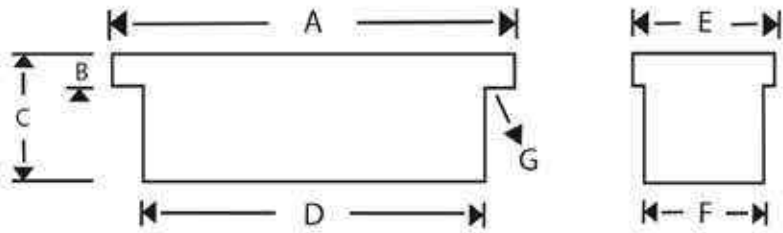

CAMLOCKER HD CROSSOVER TOOLBOXES								
Product Code	A	B	B LP*	C	D	E	F	G
Standard HD	71"	6"	3"	14"	60 1/2"	20"	17"	5"
King HD	71"	6"	3"	19"	60 1/2"	20"	17"	5"
Xtra Deep & Wide	71"	6"	3"	19"	60 1/2"	20"	17"	5"

KING HD



XTRA DEEP & WIDE



CAMLOCKER CROSSOVER TOOLBOX



CAMLOCKER KING CROSSOVER BOX



KEY FEATURES:

The king allows you to have 25% more storage space measuring 19" deep with lid included.

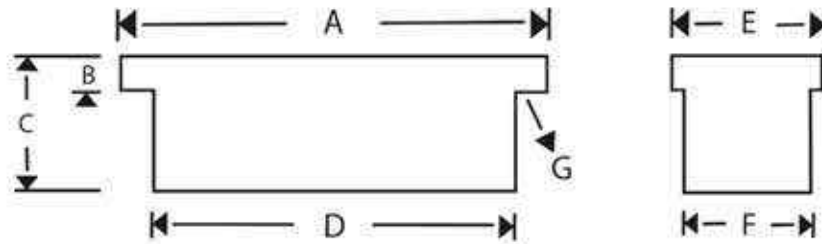

King Size: 20" Wide x 19" Deep								
Product Code	A	B	B LP*	C	D	E	F	G
CAM/KS-71	71"	6"	3"	19"	60 1/2"	20"	17"	5"
CAM/KS-67	67"	6"	3"	19"	56 1/2"	20"	17"	5"
CAM/KS-65	65"	6"	3"	19"	54 1/2" Y - 52 1/2"	20"	17"	5"
CAM/KS-63	63"	6"	3"	19"	52 1/2"	20"	17"	5"
CAM/KS-60	60"	6"	3"	19"	49 1/2" Y - 47 1/2"	20"	17"	5"
CAM/KS-54	54"	6"	3"	19"	43 1/2"	20"	17"	5"

CAMLOCKER KING CROSSOVER BOX



CAMLOCKER DEEP AND WIDE CROSSOVER TOOLBOX

CAMLOCKER DEEP AND WIDE

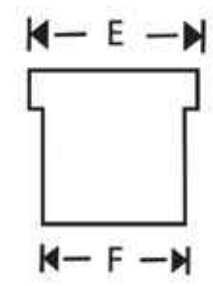
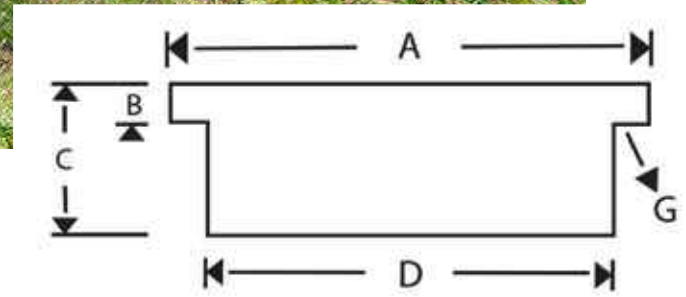
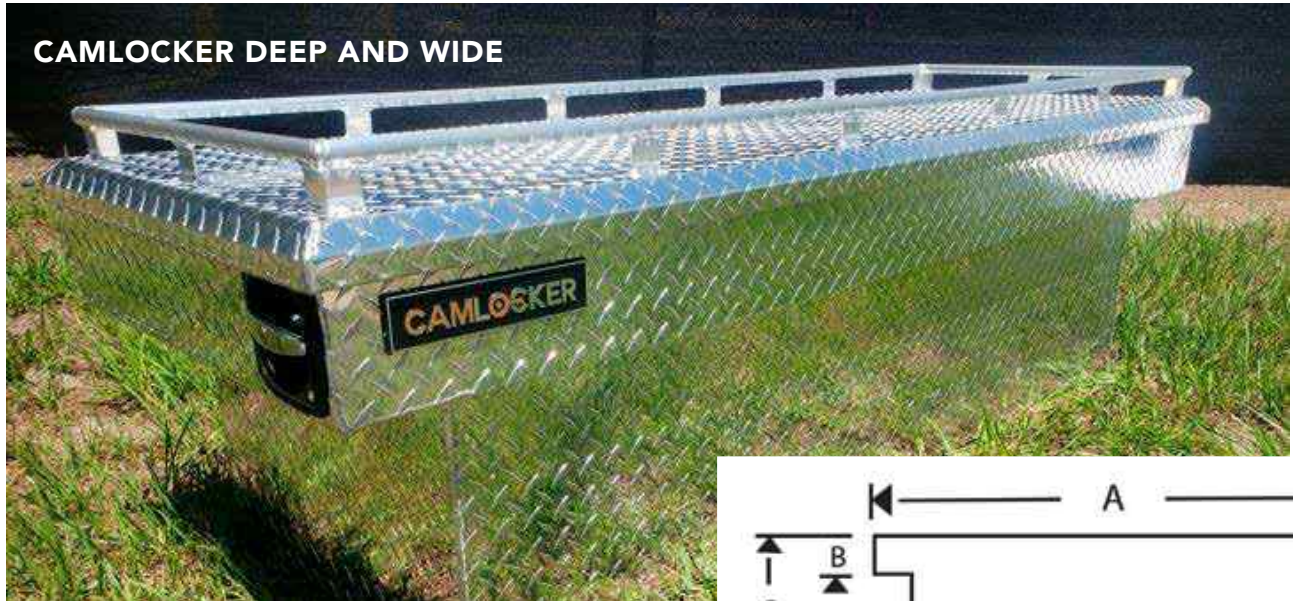

- KEY FEATURES:**
- Adds 4.5" to the width and 2" to the depth compared to the Camlocker standard crossover.
 - The deep & wide adds 30% more storage compared to the standard crossover.

Deep & Wide 24.5" Wide x 16" Deep								
Product Code	A	B	B LP*	C	D	E	F	G
CAM/S 71 DW	71"	6"	3"	16"	60 1/2"	24.5"	21.5"	5"

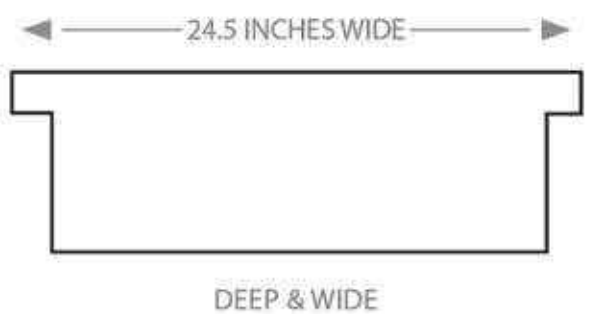
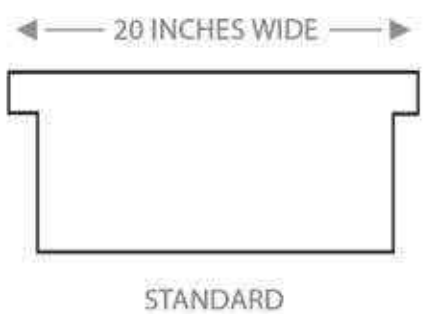

CAMLOCKER XTRA DEEP & WIDE SPECIFICATIONS

THE XTRA DEEP & WIDE:

Measures 19" deep (lid included) x 24.5" wide and is currently available in the 71 series. The profile options are again 6" above the bed-rail for the Standard or 3" for the LP. As the largest offering in the CamLocker line-up, the UN notching system are sure to provide the look and fit you expect from CamLocker. As with all of our boxes the XDW has our polished aluminum, matte or gloss black finish options.

Key Features

- Adding 4.5: to the width and 5" to the depth of the box
- Adds 40% more storage space

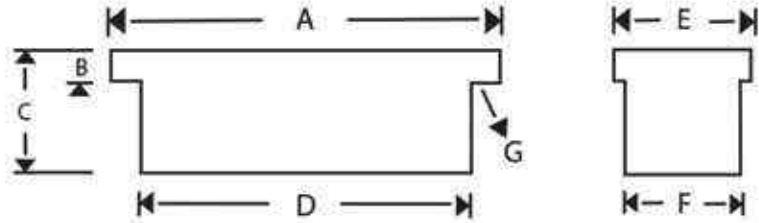

Xtra Deep & Wide: 24.5" Wide x 19" Deep

Product Code	A	B	B LP*	C	D	E	F	G
CAM/KS-71 XDW	71"	6"	3"	19"	60 1/2"	24.5"	21.5"	5"

* LP=LOW PROFILE

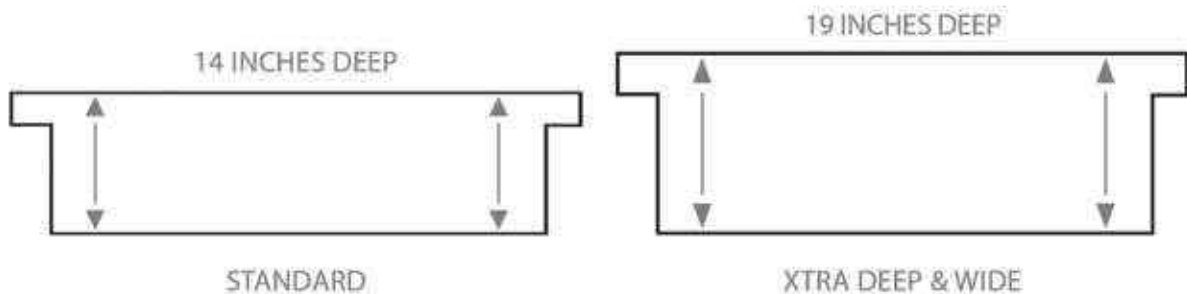

THE CAMLOCKER SLIMLINE



SLIMLINE KING SIZE (KS),
LOW PROFILE (LP)



THE SLIMLINE

With today's rise in the popularity of Crew Cabs and other extended cabs, the cargo beds continue to get smaller and smaller. The Slimline series is perfect for lockable protection without sacrificing your bed space.

The SL model comes in at the same standard depth of 14" top to bottom (lid included) but with a reduced cab to tailgate measurement of 14" instead of the standard 20". Available in all series. The KSL has the same features but provides the same depth as our King Size model at 19" top to bottom (lid included).

CAMLOCKER SLIMLINE CROSSOVER TOOLBOX

THE SLIMLINE:

Measures 14" deep (lid included) on the standard or 19" deep (lid included) on the king and measures 14" wide on any series from 54" to 71". As with our other lines, both profiles, Standard and Low Profiles are available. While the Slimline models are designed for shorter bed lengths our unique notching system is still available to accommodate appropriate fit. As with all of our boxes, the Slimline has our polished aluminum, matte or gloss black finish options.

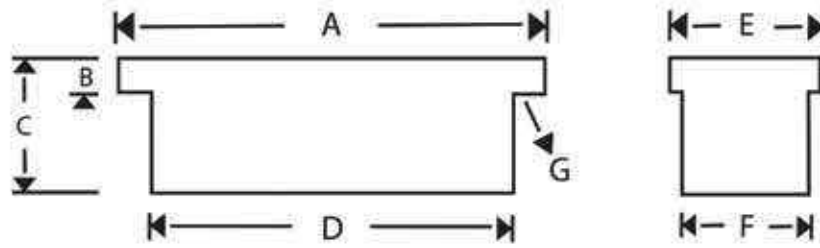

KEY FEATURES

- Designed for trucks with limited space
- The slim line box is most popular with our outdoor sportsmen, used in their truck beds for more space for dog boxes
- Measures 14" deep for standard box and 19" deep for the king box
Either 14" or 18" wide on any length from 54" to 71" boxes

Slim Line: 14" Wide x 19" or 14" Deep								
	A	B	B LP*	C	D	E	F	G
CAM/KSL-71A	71"	6"	3"	19"	60 1/2"	14"	11"	5"
CAM/SL-71A	71"	6"	3"	14"	60 1/2"	14"	11"	5"
CAM/KSL-67A	67"	6"	3"	19"	55 1/2"	14"	11"	5"
CAM/SL-67A	67"	6"	3"	14"	56 1/2"	14"	11"	5"
CAM/KSL-65A	65"	6"	3"	19"	54 1/2"	14"	11"	5"
CAM/SL-65A	65"	6"	3"	14"	54 1/2"	14"	11"	5"
					Y - 52 1/2"			
CAM/KSL-63A	63"	6"	3"	19"	52 1/2"	14"	11"	5"
CAM/SL-63A	63"	6"	3"	14"	52 1/2"	14"	11"	5"
CAM/KSL-60A	60"	6"	3"	19"	49 1/2"	14"	11"	5"
CAM/SL-60A	60"	6"	3"	14"	49 1/2"	14"	11"	5"
					Y - 47 1/2"			
CAM/KSL-54A	54"	6"	3"	19"	43 1/2"	14"	11"	5"
CAM/SL-54A	54"	6"	3"	14"	43 1/2"	14"	11"	5"

NOTE: FOR 18" WIDE SLIMLINE, DROP THE M IN THE MODEL NUMBER *LP=LOW PROFILE

CAMLOCKER SLIMLINE





THE CAMLOCKER RECREATIONAL VEHICLE "RV" BOX

Great for use as an in-bed toolbox if you prefer it not to sit on the rails but finish with more of a flush look. The RV box can be used as a dock-box for use by the water or as the name suggests in the cargo hold in your RV. The RV series originally got its start at AAA, Inc. and CamLocker as a tack box in the horse and livestock markets.

BL = Bevel = 4" x 4" 45° angle in bottom left and right hand corners. Recommended for use in truck beds. Available on all models except the 36.

FN = Full Notch = up step/stair shape notch in bottom left and right hand corners to accommodate for wheel wells. Available on 53's.

SCN = Super Crew Notch = To accommodate wheel wells. Available on 57's & 60's.

CAMLOCKER "RV" BOX

THE RECREATIONAL VEHICLE BOX:

Measures 20" x 20" for the width and height with available lengths of 36, 48, 53, 57 & 60. With a design concept focusing on versatility, let your imagination run wild with possible usage ideas.

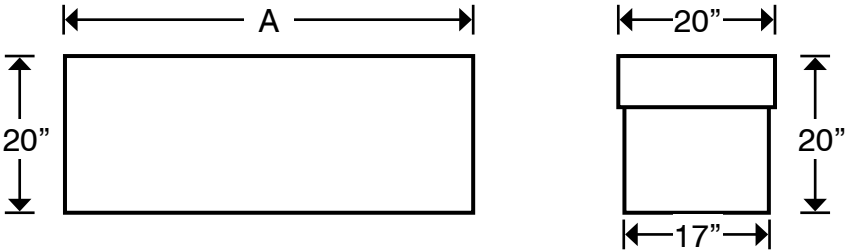

KEY FEATURES

- Measures 20 x 20 for the width and heights available lengths 36, 48, 53, 57 & 60.
- Dual locking handles for additional storage
- Lid self opens at a 90 degree for convenient open

RV Box: 20" Wide x 20" Deep	
Product Code	A
CAM/RV-36	36"
CAM/RV-48	48"
CAM/RV-53	53"
CAM/RV-57	57"
CAM/RV-60	60"



CAMLOCKER SIDE MOUNT TOOLBOXES



PRODUCT DETAILS:

- Offering sidemount toolboxes in standard or low-profile for more visual
- Mounts on the inside of the truck bed for additional truck bed space
- Locking t-handles for additional storage

Side Mount Box: 12" Wide x 12" Deep

Product Code	A
CAM/SMB-36	36"
CAM/SMB-48	48"
CAM/SMB-60	60"
CAM/SMB-68	68"
CAM/SMB-72	72"



CAMLOCKER UTV BOXES & SIDEMOUNT

FEATURED PRODUCTS:



PRODUCT DETAILS

- Built to keep luggage or tools secure while riding outdoors
- Built with our Camlocker locking stainless steel locks for security
- Easy opening access on both sides
- Tight seal to keep dust and dirt out



UTV BOXES BUILT FOR:

- Polaris Ranger
- Polaris Razor
- Honda Pioneer
- Can-am Defender
- Kawasaki
- Yamaha



CAMLOCKER SIDEMOUNT BOXES

CAMLOCKER SIDE TOP MOUNT TOOLBOX & UNDERBODY BOX



CAMLOCKER MODEL + FEATURES

CAMLOCKER COLLECTION



CLASSIC



KING SIZE



DEEP & WIDE



XTRA DEEP & WIDE



SLIM LINE



SIDE MOUNT



RV



FRONT LOCK (LOW PROFILE)



SIDE LOCK (STANDARD PROFILE)



LOCKING CAM MECHANISM



INSULATED - WEATHER STRIPPED



INTERIOR CARPET



SLIDING TRAY*

*SLIDING PLASTIC TRAY COMES STANDARD. METAL TRAY AVAILABLE FOR UPGRADE.

FIT GUIDE + OPTIONS

Toolboxes	Make	Models/Cab Styles	Years
Cam/S-71 LP Cam/S-71	Chevy Ford Dodge Nissan Toyota	All Fullsize All Fullsize (Excluding 97-03 Crew Cabs) All Fullsize All Titan's Tundra	99-Current 04-Current 02-Current 03-Current 07-Current
Cam/KS-71	Chevy Ford Dodge Nissan Toyota	All Fullsize All Fullsize (Excluding 97-03 Crew Cabs) All Fullsize Titan (Excluding Crew Cabs) Tundra	99-Current 04-Current 02-Current 03-Current 07-Current
Cam/KS71 LP	Chevy Ford Dodge Dodge Nissan Toyota	Fullsize Regular & Quad Cabs Fullsize Regular & Quad Cabs All Fullsize Fullsize Regular Cabs Titan Regular & Quad Cabs Tundra Regular & Quad Cabs	99-Current 97-Current 02-08 02-Current 03-Current 07-Current
Cam/KS-71 LP UN	Chevy Ford Dodge Nissan Toyota	Fullsize Crew Cabs Fullsize Crew Cabs Fullsize Quad & Crew Cabs Titan Crew Cabs Tundra Quad & Crew Cabs	07-Current 04-Current 09-Current 03-Current 07-Current
CAM/S-67	Toyota	T-100 All Cab Sizes	99-07
CAM/KS-67 LPN CAM/KS-67 N	Toyota	T-100 Quad & Crew Cabs	99-07
CAM/S-63 FN CAM/KS-63 FN CAM/S-63 LP FN CAM/KS-63 LP FN	Toyota	Tacoma	05-Current
CAM/S-63 FN CAM/KS-63 FN CAM/S-63 LP FN CAM/KS-63 LP FN	Nissan Dodge	Frontier Dakota Crew Cabs	04-Current 97-11
CAM/S-63 CAM/KS-63 CAM/S-63 LP CAM/KS-63 LP	Dodge	Dakota Regular & Quad Cabs	97-11
CAM/S-65 Y CAM/KS-65 Y CAM/S-65 LP Y CAM/KS-65 LP Y	Ford	Flairside	97-Current
CAM/S-54 CAM/KS-54 CAM/S-54 LP CAM/KS-54 LP	Ford Chevy	Flairside Sportside	92-97 88-99
CAM/S-60 Y CAM/KS-60 Y CAM/S-60 LP Y CAM/KS-60 LP Y	Chevy Chevy Ford	Sportside S-10, S-15, Sonoma	00-Current All Years All Years
CAM/S-63 CAM/S-63 LP CAM/KS-63 FN CAM/KS-63 LP FN	Chevy	Colorado Regular Cab	04-Current
CAM/S-63 FN CAM/KS-63 FN CAM/S-63 LP FN CAM/KS-63 LP FN	Chevy	Colorado Quad & Crew cabs	04-Current

HUNTING ACCESSORIES

ALL PRODUCTS OFFERED IN MATTE BLACK OR ALUMINUM FINISH



Dogboxes with added on accessories for additional pricing:

- 48x34x24
- 48x48x24



Water Tanks:

- 6x6x36
- 6x6x48



Collar Boxes:

- 20x20x7
- 30x32x7



Cooler rack and one gallon spill proof water dish

We are proud to serve you with
American Hand Crafted products!

Located in Perry, Florida

CAMLOCKER TOOLBOXES

3382 US HWY 19 South

Perry, Florida 32348

Email: sales@camlockeonline.com

CAMLOCKER

CRAFTED WITH PRIDE IN THE U.S.A.

CamLocker - LIMITED LIFETIME WARRANTY. REGISTER ONLINE AT www.CamLockerOnline.com. Registering will activate the Limited Lifetime Warranty. You may also call or mail your warranty in to complete the registration process. Failure to register your product within 14 days of the date of purchase listed on your receipt will result in loss of coverage as detailed below. Limited Lifetime Warranty American Aluminum Accessories, Inc. (manufacturer) guarantees a limited lifetime warranty of materials and workmanship of the equipment due to normal use. The Limited Lifetime warranty remains in effect and applies to the original purchaser ("purchaser") of a new product. A new product is defined as Newly Installed CamLocker Toolbox. The warranty lasts for as long as the original purchaser owns the vehicle on which the product was originally installed. The warranty is not transferable from purchaser to any subsequent owner and/or vehicles. The warranty immediately terminates if product is removed from the original vehicle or if vehicle transfers ownership. Modification of any kind voids all warranty coverage. Warranty is limited to replacement or repair of genuine American Aluminum Accessories, Inc products. **See Bottom Conditionally Covered Items Wear and operational items such as shocks, latches, hinges, hardware, gaskets, keys, lift-cylinders, etc...are covered for 3 years/36 months from date of purchase on receipt. Replacements can be ordered via credit card by calling 1-800-277-0869. Powder coating carries a 1 year or 12 months from date of purchase warranty. Coverage extends through both currently available options of matte & gloss black. The high quality finish must be cared for and maintained like any other exposed finish. Protect the finish with non-abrasive auto-wash on a regular basis. Compounds with abrasive materials may scratch the finish and leave exposed areas susceptible to blemishing. All Warranty Claims must be initiated at the place of purchase. Original receipt proof of purchase, displaying the date and registered warranty must accompany all claims along with photographs referencing defect. What is not covered: Buyer assumes all risk, liability, cost for installation and use of American Aluminum Accessories, Inc products. All products are sold functionally as lifestyle products for work and play and are not relied upon as protection for the vehicle or its occupants in the event of an accident. The warranty does not cover re-installation, cost of removal, labor, transportation costs, loss of use, inconvenience or consequential damages. Warranty excludes damage resulting from misuse, abuse, accident, improper installation (when not installed by American Aluminum Technicians), modification of any kind, vandalism, spills, improper or inadequate maintenance or on-road and off-road hazards to the original purchaser.

**THIS LIMITED WARRANTY DOES NOT COVER LABOR COSTS or incidental, indirect, special or consequential damages such as, but not limited to, physical injuries or property damage, loss of time, loss of use of the vehicle, inconvenience, rental vehicle charges, towing charges or accommodations resulting from a defect in or failure of the part. This limited warranty represents the exclusive remedy for any product defect or failure and the total liability of American Aluminum Accessories, Inc., and its subsidiaries and affiliates ("AAA") for any part it warrants. AAA MAKES NO OTHER WARRANTIES, EXPRESS OR IMPLIED, INCLUDING ANY WARRANTIES OF MERCHANTABILITY, CONDITION OF ANY KIND OR FITNESS FOR A PARTICULAR PURPOSE. Some states do not allow disclaimers of implied warranties. Therefore all implied warranties that may apply to your purchase are limited to the duration of this written warranty. Some states also do not allow limitations on how long an implied warranty lasts or the exclusion or limitation of incidental, special or consequential damages, so the above information may not apply to you. This warranty gives you specific rights, and you may have other rights which vary from state to state. AAA does not authorize any person to vary the terms, conditions or exclusions of this warranty. If any provision of the warranty should become invalid or unenforceable because of any laws, the remaining terms and provisions of the warranty shall remain in full force and effect. To the extent allowed under local law, the remedies provided in this Limited Warranty Policy are the customer's sole and exclusive remedies.

EMPLOYEE DIRECTORY

Arnold, Jennifer	General Manager	jennifera@aaa-mail.com
Swain, Marisol	Director of Operations	marisols@aaa-mail.com
Eastman, Matthew	Toolbox Sales	matthewe@aaa-mail.com
Hall, Alicia	Logistics	aliciah@aaa-mail.com
Hatch, Courtney	Sales	courtneyh@aaa-mail.com
Meyer, David	Design	davidm@aaa-mail.com
Murphy, Jonathan	Sales	jonathanm@aaa-mail.com
Phelps, Brandon	Design	brandonp@aaa-mail.com
Lee, Brian	Design	brianl@aaa-mail.com
Poppell, Kaleb	Electronics	kalebp@aaa-mail.com
Shreve, Leann	Sales	leanns@aaa-mail.com
Streetman, Kim	Sales	kims@aaa-mail.com
Strickland, Britney A	Sales	britneys@aaa-mail.com
Vann, Joey	Design	josephv@aaa-mail.com



AMERICAN ALUMINUM
ACCESSORIES, LLC.